

New Home-Janome Model 575

Instruction Manual

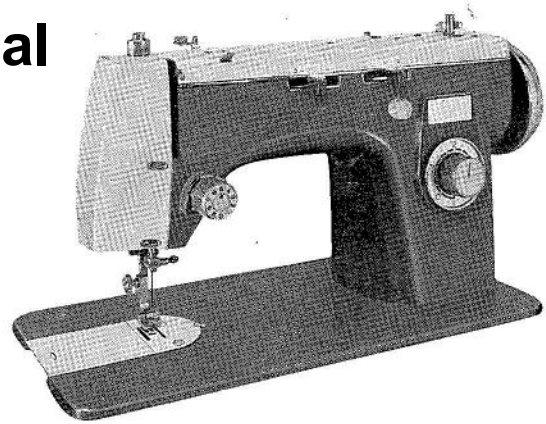

MODEL 575

CONTENTS

NAMES OF PARTS	4	TO START SEWING	13
TO REMOVE BOBBIN CASE	6	TO REGULATE THREAD TENSIONS	14
TO WIND BOBBIN	6	TENSION OF UPPER THREAD.....	14
TO ADJUST BOBBIN WINDING DEVICE	8	TENSION OF LOWER THREAD	15
TO THREAD BOBBIN CASE	9	TO USE BUILT-IN SEWLIGHT	15
TO INSERT BOBBIN CASE INTO SHUTTLE RACE	10	TO ADJUST PRESSURE ON PRESSER FOOT	16
TO INSERT NEEDLE.....	10	TO USE DROP-FEED DEVICE	16
RIGHT NEEDLE AND THREAD FOR RIGHT CLOTH.....	11	TO REGULATE LENGTH OF STITCH AND DIRECTION OF FEED	17
TO THREAD NEEDLE	12	ZIGZAG WIDTH REGULATOR	18
TO DRAW OUT LOWER THREAD...13		NEEDLE POSITION SELECTOR	18

ZIGZAG SEWING	19
MANUAL ZIGZAG SEWING.....	20
BUTTONHOLE SEWING	21
HEMMING	23
SEWING IN A ZIPPER.....	24
DARNING AND EMBROIDERY	25
BLIND STITCH HEM	26
TO CLEAN SHUTTLE RACE.....	27
TO OIL MACHINE	28
CARE AND ADJUSTMENT OF MOTOR	29
SUGGESTIONS FOR SMOOTH SEWING	31

NAMES OF PARTS

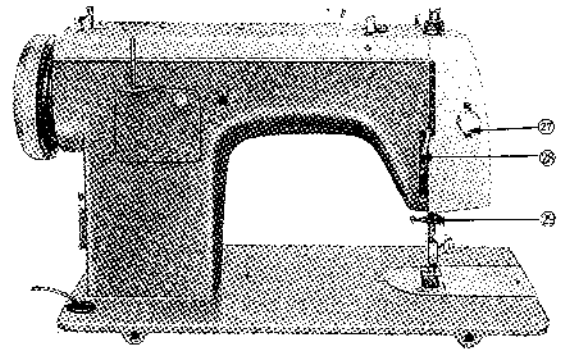
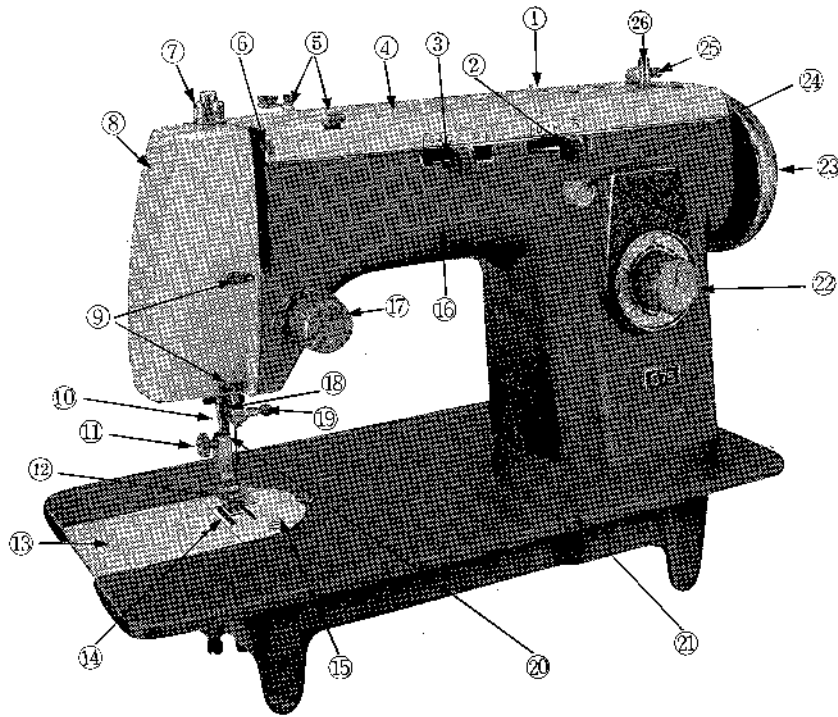

NAMES OF PARTS

- | | | |
|----------------------------|----------------|--------------------------------|
| ① Arm spool pin | ⑩ Presser bar | ⑮ Needle |
| ② Needle position selector | ⑪ Thumb screw | ⑯ Needle clamp |
| ③ Zigzag width regulator | ⑫ Presser foot | ⑰ Needle bar |
| ④ Top cover | ⑬ Slide plate | ⑱ Bed |
| ⑤ Top cover thread guides | ⑭ Feed dog | ⑲ Needle clamp |
| ⑥ Thread take-up lever | ⑮ Needle plate | ⑳ Needle |
| ⑦ Patchomatic darning | | ㉑ Bed |
| ⑧ Face plate | | ㉒ Stitch length regulator dial |
| ⑨ Face plate thread guides | | ㉓ Hand wheel |
| | | ㉔ Zigzag width stopper knob |
| | | ㉕ Bobbin winder spindle |
| | | ㉖ Bobbin winder latch |
| | | ㉗ Light switch |
| | | ㉘ Presser bar lifter |
| | | ㉙ Thread cutter |

TO REMOVE BOBBIN CASE

Turn the hand wheel toward you until the needle bar is at its highest point.

Open the slide plate in the bed of the machine so that the bobbin case can be reached.

Insert the thumb and forefinger to open the latch and withdraw the bobbin case.

While the latch is held open, the bobbin is retained in the bobbin case and will not drop out.

On releasing the latch and turning the bobbin case downward, the bobbin will drop out.

The bobbin case must never be removed when the needle bar is in the lower position.

Neither should a bent needle be used, as it is liable to damage the bobbin case or the shuttle.

TO WIND BOBBIN

1) While holding the balance wheel with your left hand, turn the stop motion screw toward you with the right hand.

This allows the balance wheel to turn freely, disengaging the stitching mechanism.

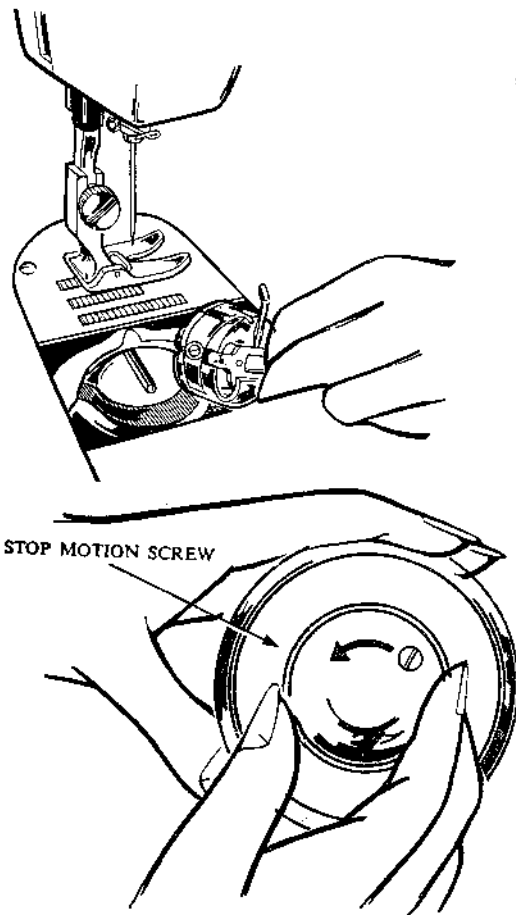

- 2) Place a bobbin on the bobbin winder spindle, revolve the bobbin until the notch in the bobbin meets the spring on the spindle, and push the bobbin down. Then push the bobbin winding spindle so that the latch fits into the bobbin. (Fig. 1)
- 3) Place a spool of thread on the spool pin.
- 4) Pass the thread between the discs of the thread guide bracket. (Fig. 3)
- 5) Pass the end of the thread through the hole in the bobbin from inside to outside. (Fig. 2)
- 6) Holding the thread with your right hand, turn the balance wheel to wind the thread several times. Then cut the free end of the thread.
- 7) Run the machine until the thread is wound 70 to 80% in the bobbin and stop the machine. Then take out the bobbin from the spindle and cut the thread.
- 8) Tighten the stop motion screw.

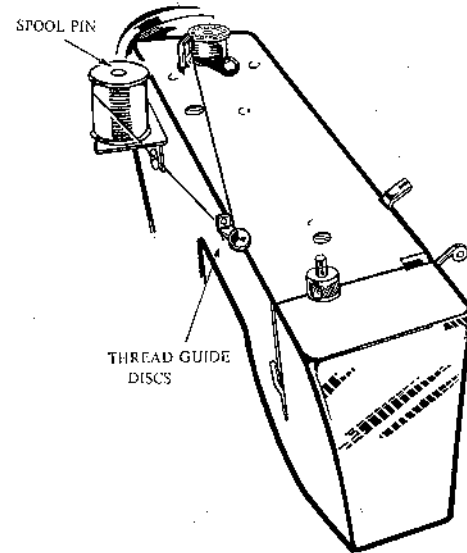
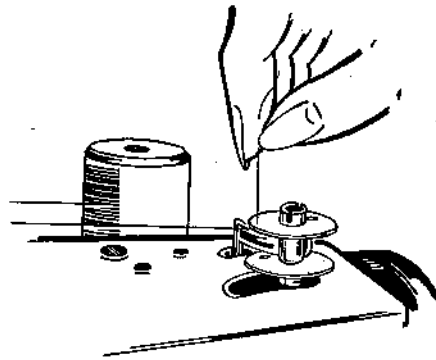
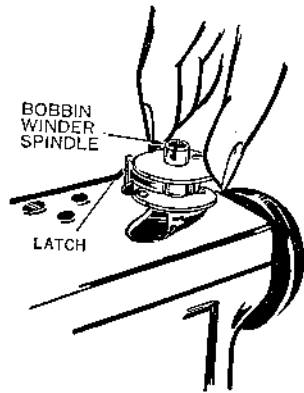

TO ADJUST BOBBIN WINDER DEVICE

The bobbin must be wound evenly. If not, irregular stitching will be the result. When the bobbin is wound excessively on the upper part of the bobbin (A), loosen the top cover thread guide set screw on the back of the top cover and lower the thread guide slightly. Tighten the screw to reset the thread guide.

When it is wound excessively on the lower part of the bobbin (B), loosen the thread guide set screw and raise the thread guide slightly. Tighten the screw to reset the thread guide.



A



B

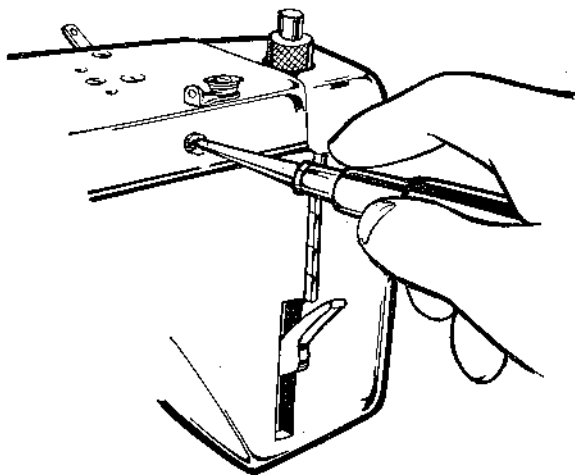

Correctly Wound

TO THREAD BOBBIN CASE

Holding the bobbin between the thumb and the forefinger of your left hand, pull out a few inches of thread.

Holding the bobbin case in your left hand, turn the open side up and place the threaded bobbin into it (Fig. 1).

Guide the thread into the slot in the edge of the bobbin case (Fig. 2).

Pull it under the tension spring and then into the delivery eye (Fig. 3).

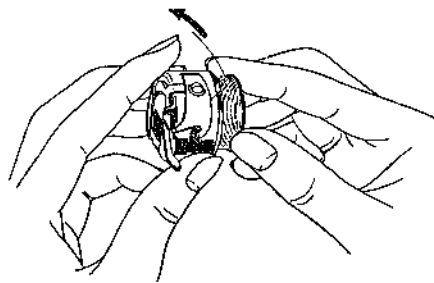

Fig. 1

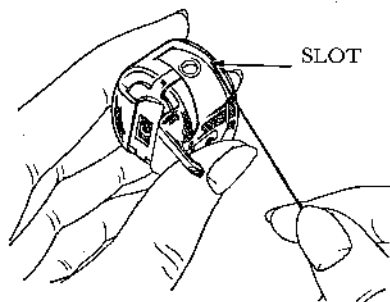

Fig. 2

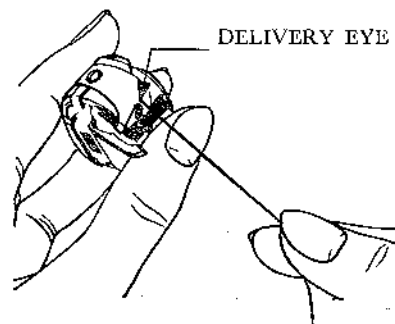

Fig. 3

TO INSERT BOBBIN CASE INTO SHUTTLE RACE

Raise the needle bar to the highest point.

Open the shuttle cover plate.

Hold the bobbin case by the latch and place it on the centre post with the bobbin case finger in the notch at the top of the shuttle.

Release the latch and press the bobbin case into the shuttle until the latch catches on the centre post with a click.

Permit the thread to hang down freely a few inches.

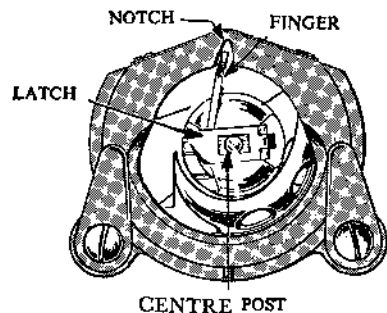

TO INSERT NEEDLE

Raise the needle bar (A) (Fig. 1) to its highest point by turning the hand wheel with your right hand.

Loosen the needle clamp screw (B) at the end of the needle bar, and insert the needle (C), with the flat side (Fig. 2) to the right, into the slot of the needle bar.

Insert the needle as far as it will go until it touches the pin which is visible in the slot above the needle clamp and tighten the needle clamp screw firmly.

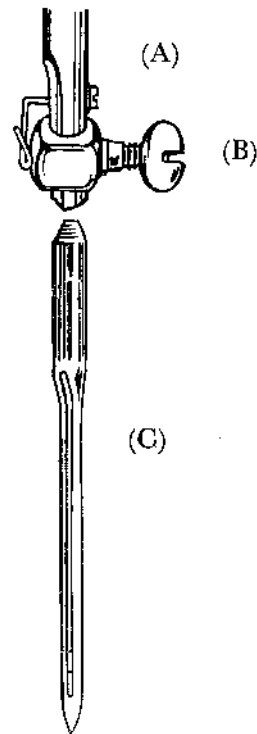

RIGHT NEEDLE AND THREAD FOR RIGHT CLOTH

Size of Needles	C l o t h	Size of Threads
No. 9	Thin calico, silk, serge and muslin.	No.80-100 cotton thread or fine silk thread.
No. 11	Thin calico, cotton cloth, crepe de Chine, hosiery and silk.	No. 60-100 cotton thread or ordinary silk thread.
No. 14	Ordinary cotton cloth, thick silk, thin woolen goods, towels and shirting.	No. 40-60 cotton thread or ordinary silk thread.
No. 16	Thick cotton cloth, serge and thin woolen goods.	No. 30-60 cotton thread or ordinary silk thread.
No. 18	Ordinary woolen goods, trousers, over-coats, thick calico and children's clothes.	No. 30-60 cotton thread or ordinary silk thread.

NOTE : Use a good quality mercerized cotton thread, if available, to avoid shrinking when laundered.

TO THREAD NEEDLE

Raise the take-up lever (6) to the highest point by turning the balance wheel toward you.

Place a spool of thread on the spool pin.

Pass the thread through upper arm thread guides (1 & 2), downwards between tension discs (3) from right to left, up over the tension thread guard (4) from behind, through the loop of the take-up spring (5), up and through the hole in the take-up lever (6), down through thread guides (7 & 8) and into the thread guide (9) at the lower end of the needle bar.

Then pass through the eye of the needle from left to right. Draw about two inches of thread through the eye of the needle.

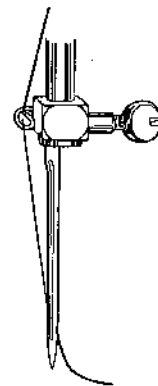
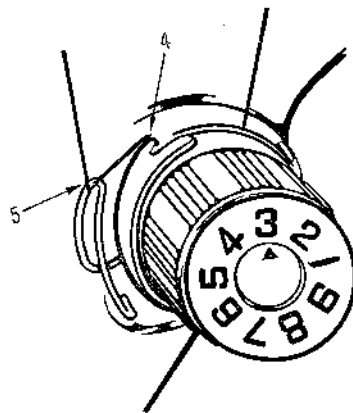
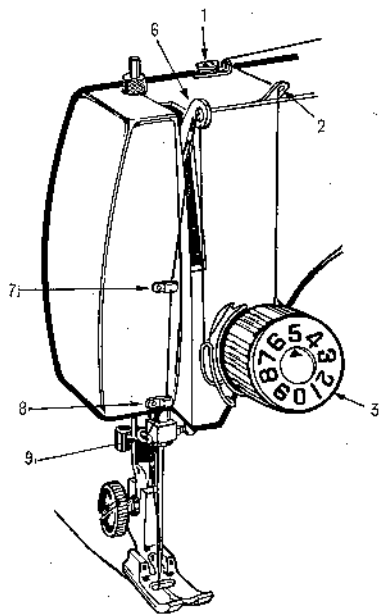

TO DRAW OUT LOWER THREAD

Hold the upper thread loosely with your left hand.
Turn the balance wheel toward you with your right hand until the needle moves down and up again to the highest point, then stop the balance wheel and pull the upper thread slowly to bring up the lower thread through the needle hole.
Place both ends of the threads back under the presser foot.

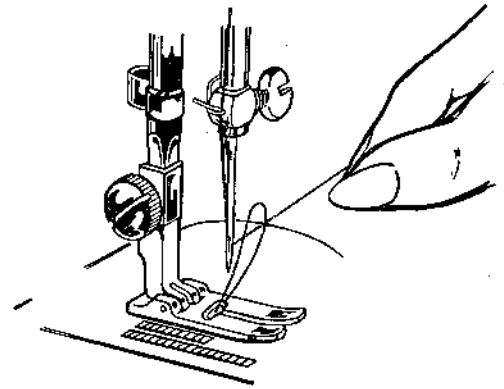

TO START SEWING

Place the cloth under the presser foot.
With the left hand hold loosely both ends of threads and turn the balance wheel by the right hand to let the needle penetrate the point from which to start sewing.
Lower the presser foot on the cloth and start sewing.

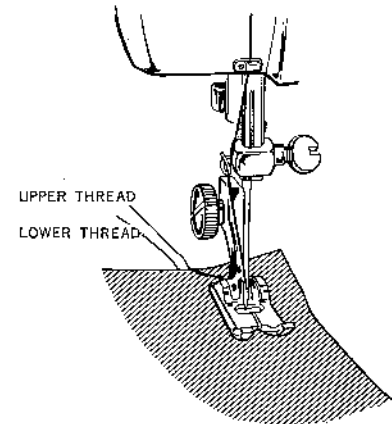

TO REGULATE THREAD TENSIONS

For ordinary stitching the tension of the upper and lower threads should be equal so as to lock both threads in the centre of the fabric. (A)

If the tension of one thread is stronger than that of the other, imperfect stitching will be the result. If the tension of the upper thread is greater than that of the lower thread, the upper thread will lie straight along the upper surface of the fabric. (B)

If the tension of the lower thread is greater than that of the upper thread, the lower thread will lie straight along the underside of the fabric. (C)

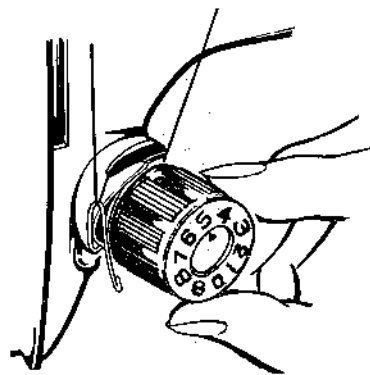
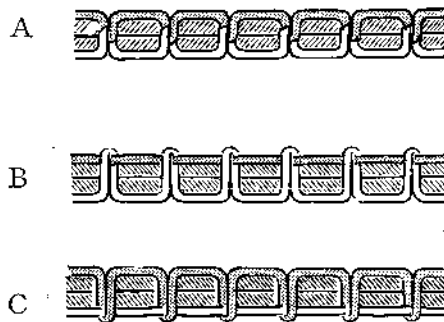

TENSION OF UPPER THREAD

The sewing machine will give perfect performance when the upper tension is correctly adjusted.

- a) The tension of the upper thread will become stronger when the thread tension dial knob is turned to the right or clockwise.
- b) The upper thread tension becomes weaker when the tension dial knob is turned to the left or anti-clockwise.
- c) When the tension has been adjusted satisfactorily, the thread tension dial can be returned to the same dial number to obtain the same result.

TENSION OF LOWER THREAD

The tension of the lower thread is regulated by a small screw on the bobbin case tension spring.

To increase the tension, tighten the screw slightly with a small driver.

To decrease the tension, loosen the screw slightly.

TO USE BUILT-IN SEWLIGHT

Swilight is turned "on" or "off" by means of the switch which is found on the back of the face plate.

To change the electric bulb, swing open the face plate. Then the bulb can be unscrewed.

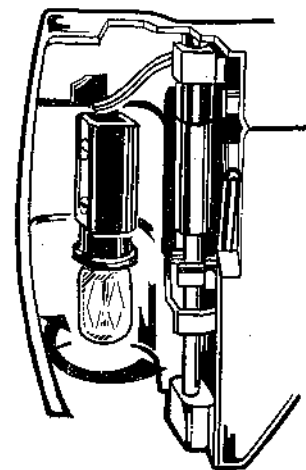
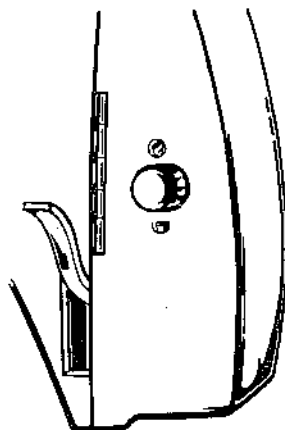
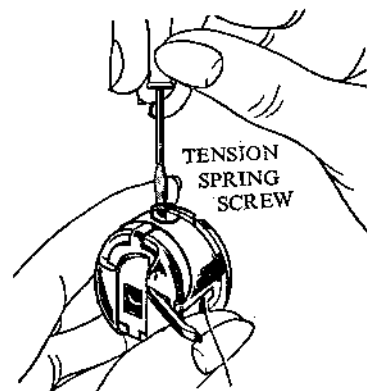

TO ADJUST PRESSURE ON PRESSER FOOT.

For releasing pressure on the foot, press down the ring (A), which will allow the darning to spring up to its highest position and leave the material free from any pressure from the presser foot.

For sewing thin or light fabrics, press the top of the darning (B) down lightly to get the required slight pressure on the fabric.

For sewing thicker or heavier fabrics, push the top of the darning down further, in order to get a stronger pressure on the presser foot.

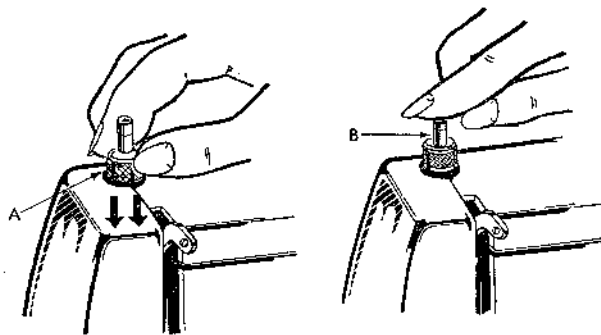

TO USE DROP FEED DEVICE

Darning and embroidering is facilitated by means of the special drop feed device which can be operated by the stitch length regulator dial.

Turn the stitch length regulator dial to the mark (X) and the feed dog will drop below the surface of the needle plate permitting the free movement of the cloth.

The feed dog resumes its normal operation when the stitch length regulator dial is turned back to "0" and over.

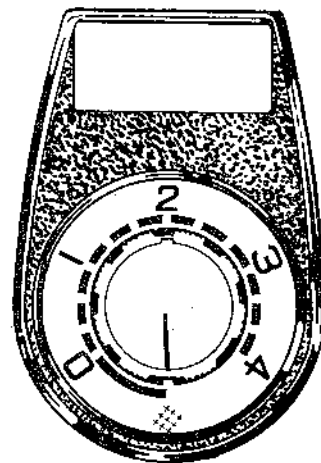

TO REGULATE LENGTH OF STITCH AND DIRECTION OF FEED

To regulate the length of stitch, turn the stitch length regulator knob to the required length.

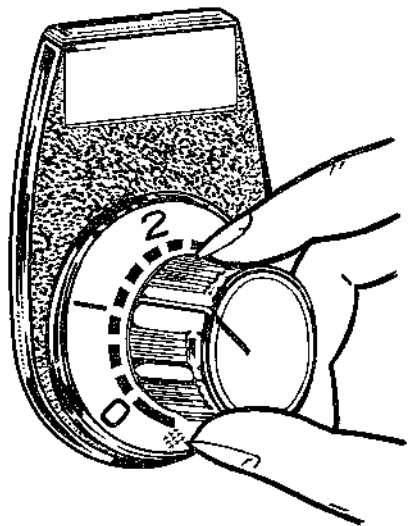

For reverse stitching, press and hold the stitch length regulator knob until the desired number of stitches are sewn.

The reverse stitching is very useful when you need a reinforced stitch.

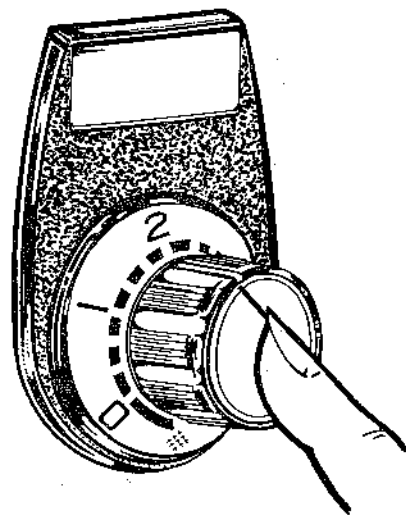

ZIGZAG WIDTH REGULATOR

For straight sewing, set the zigzag width regulator at "0".

By moving the zigzag width regulator to the left or to larger numbers of the scale, zigzag width is increased accordingly.

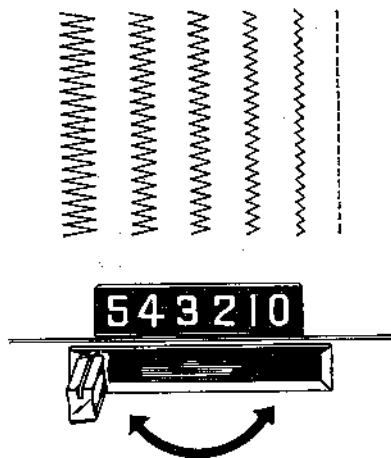

NEEDLE POSITION SELECTOR

With the zigzag width regulator set at "0" and the needle position selector at "L", the machine sews a straight line at the left position.

With the needle position selector at "M" and "R" the machine sews at the center position and the right respectively.

As the zigzag width increases, the machine sews stitching patterns as shown here at each needle position.

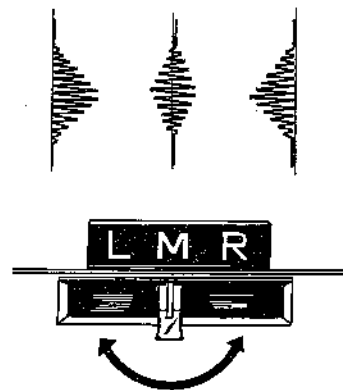

ZIGZAG SEWING

Make sure needle plate and the presser foot are for zigzag use.

The controls for zigzag stitch are located on the arm of the machine as shown in the figure.

Notice the regulator "A" which adjusts width of zigzag seams. By moving this regulator gradually to the left toward "5" the machine will sew a zigzag seam of increasing width, depending on the position of the regulator.

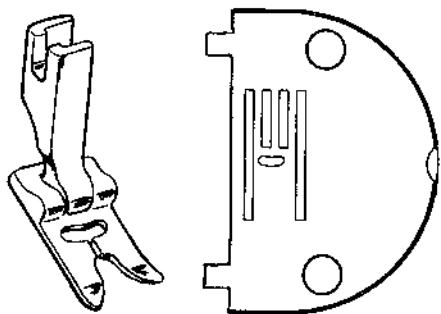



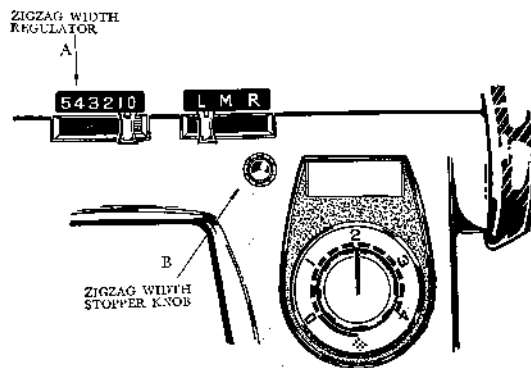













When sewing buttonholes, the zigzag width stopper knob will be found useful. This stop lock serves as a stop for the regulator "A". To set the regulator "A", loosen the zigzag width stopper knob "B", move the regulator to the desired position, tighten the zigzag width stopper knob "B".

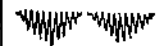

MANUAL ZIGZAG SEWING

By manually adjusting the stitch length, zigzag width and needle position while running the machine, a variety of ornamental stitches are sewn.

The following are some examples of manually sewn ornamental stitches:

Patterns	Stitch Length	Width	Needle Position	Patterns	Stitch Length	Width	Needle Position
	any length	0	any position		any length	5-2-5	M
	short	5	"		"	"	R
	any length	1~5	"		"	slowly 0 to 5 and quickly to 0	L
	"	0-5-0	L		"	"	M
	"	"	M		"	"	R
	"	"	R		"	2.5	alternatively L-R
	long and short (repeat)	any width	any position		"	1.5	L-M-R-M-L
	any length	2-5-2	L		"	2	slowly L-R-L

BUTTONHOLE SEWING

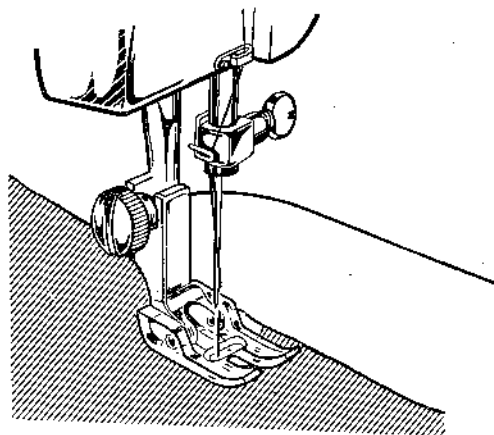

Replace the presser foot with the plastic buttonhole foot and set the needle position selector at "L". Set the zigzag width regulator at "2.5" and the stitch length regulator dial at "0.5". (Less if stitches are too far apart—slightly more if the stitches are too close together.) With a pencil or tailor's chalk, mark the position and the length of the buttonhole on the fabric.

Set the fabric on the machine bed with the starting point of buttonhole (A) underneath the needle and sew slowly to the point (B).

To sew the bar tack, turn the stitch length regulator dial to the mark (X) and set the zigzag width regulator at "5". Sew four or five stitches by turning the hand wheel toward you by your right hand and stop the machine when the needle comes to the point (C).



Before sewing the other row of the buttonhole, set the zigzag width regulator at "3" and the stitch length regulator dial at "0.5". Turn the hand wheel to bring the needle to the point (D).

Raise the presser bar lifter and turn the fabric around 180 degrees.

Bring the needle to the highest point by turning the hand wheel to reset the zigzag width regulator at "2.5".

Now lower the presser bar lifter and commence sewing the other row and the bar tack in the same way.

To lock the thread, set the zigzag width regulator at "0", turn the stitch length regulator dial to the mark (X) and sew a few stitches.

Cut the slot of the buttonhole with a buttonhole cutter or a seam ripper carefully not to cut through the bar tacks.

Note:

When moving zigzag width regulator, the needle must be raised up from the fabric lest the needle be bent or broken.

To make a heavier buttonhole, sew twice by repeating the same procedure.

It is recommended to make some samples on a piece of cloth to get the correct stitch settings.



HEMMING

Raise the needle to its highest point.

Raise the presser bar, regular presser foot, and attach a hemmer foot, and attach a hemmer foot.

Set the needle position selector at "L".

Fold over the edge of the fabric approximately 1/8 inch wide, then fold it over again in the same way for a length of about 2 inches.

Insert this folded end below and into the spiral-formed opening (scroll) of the hemmer foot.

Move the fabric back and forth until the hem forms itself in the scroll.

Pull the fabric toward you until the beginning of the hem is just below the needle.

Guide the fabric into the hemmer foot while proceeding

Note : Do not crowd fabric into the scroll, nor leave the scroll only partly filled with fabric.

Instead of a straight stitch, you can also use a zigzag stitch for this hemming operation.

Be sure, however, to adjust the width of the zigzag stitch so that it is as wide as the hem itself.

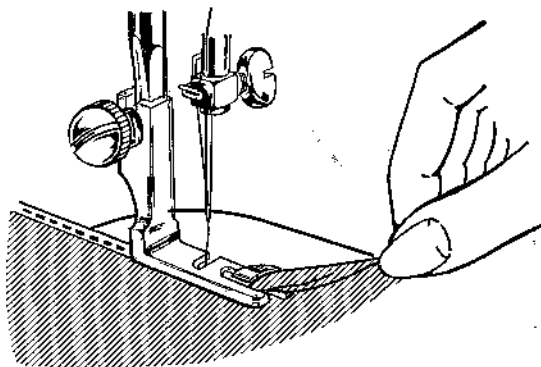

SEWING IN A ZIPPER

The zipper foot included in the accessories enables you to attach a zipper on fabric.

Remove the regular presser foot and attach the zipper foot to the presser bar of the machine.

First open out the zipper and place fabric in the position under the needle.

Set the machine for straight stitching.

Loosen the thumb screw (A) to set the foot on the left side of the needle and sew the left-side zipper as shown.

To sew the right-side zipper, bring the foot to the right side of the needle

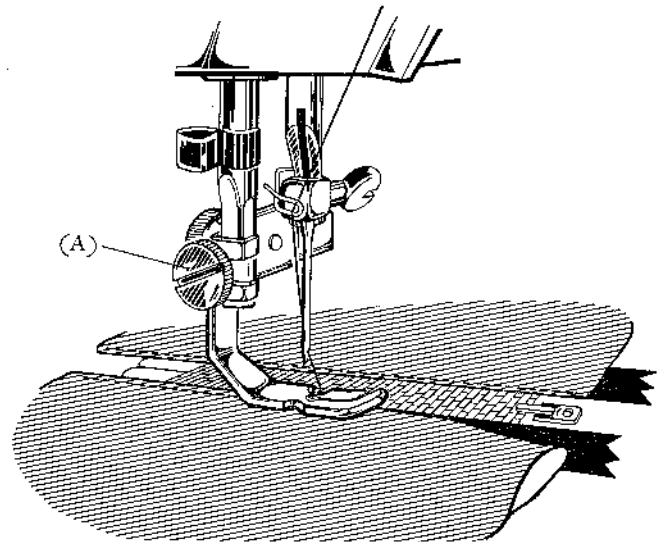

DARNING AND EMBROIDERY

Raise the presser bar lifter and remove the presser foot.

Set the stitch length regulator dial to the mark ().

Now your machine is ready for embroidery and darning.

Embroidery will be done most successfully when the fabric is stretched and fixed in an embroidery hoop.

Hold the hoop closely on the machine bed with both hands, press the material with your left forefinger in the vicinity of the needle.

This will help in holding down the material and will prevent the machine from making skipped stitches. Manipulate work carefully and be sure to keep fingers out of the path of the needle.

Adjust thread tensions for the best appearance of embroidery work and slightly increase the bobbin thread tension to avoid the lower thread from being pulled up.

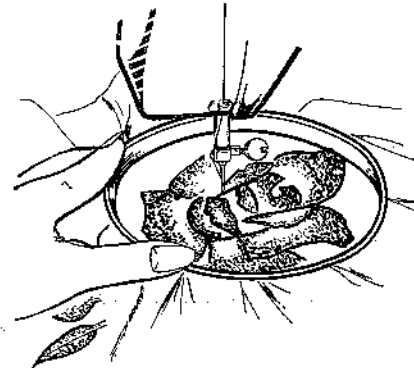
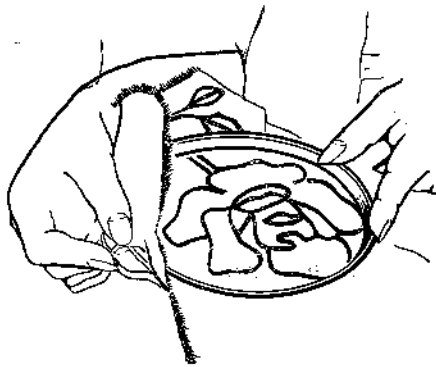

BLIND STITCH HEM

With the fabric inside out, fold it to the desired size of the hem. (No. 1)

Fold it again with a $\frac{1}{16}$ inch overlap on the bottom fold. (No. 2)

Set the zigzag width regulator at "3" and the stitch length regulator dial at about "2", and sew on the fold. (No. 3)

Then unfold the fabric, and you will have a blind stitch hem. (No. 4)

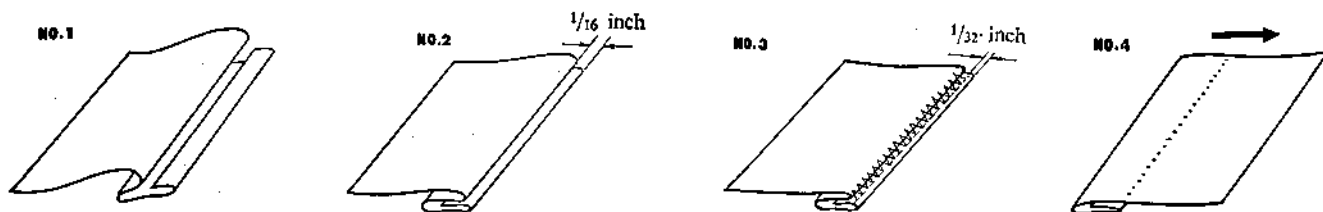

TO OPEN SHUTTLE RACE

Because your machine is specially equipped with the shuttle thread ejector which prevents jamming of the shuttle, it will rarely be necessary to open and clean the shuttle-race.

However, if for some reason it should ever be required to open and clean the shuttle-race,

First raise the needle bar to its highest point and remove the bobbin case.

Next, twist the shuttle-race ring clasps outward and take out the shuttle-race ring.

Carefully remove shuttle hook and clean out shuttle-race.

Replace shuttle hook, shuttle-race ring and lock with clasps.

Be careful not to drop or otherwise damage the shuttle.

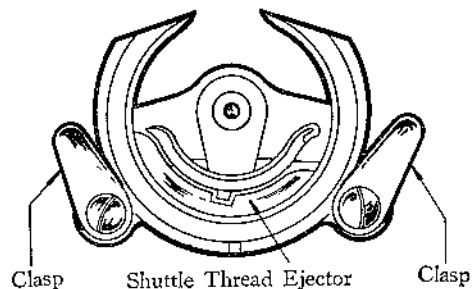

Shuttle Hook

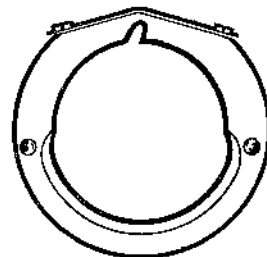

Shuttle Race Ring

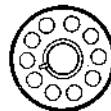

Bobbin

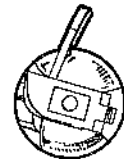

Bobbin Case

TO OIL MACHINE

Apply a few drops of fine quality sewing machine oil to the points indicated by the arrows in the figures.

In constant use, oil two or three times a week.

In case the machine does not work smoothly due to standing idle for some time, apply a few drops of kerosene at the oiling points, and run the machine rapidly for a minute.

Before lubricating, wipe off the oiling points.

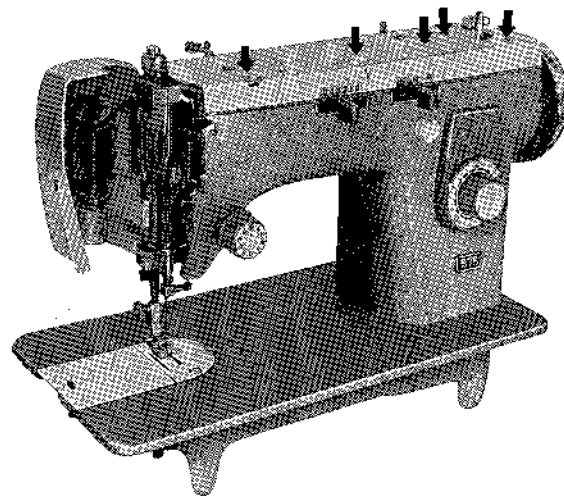
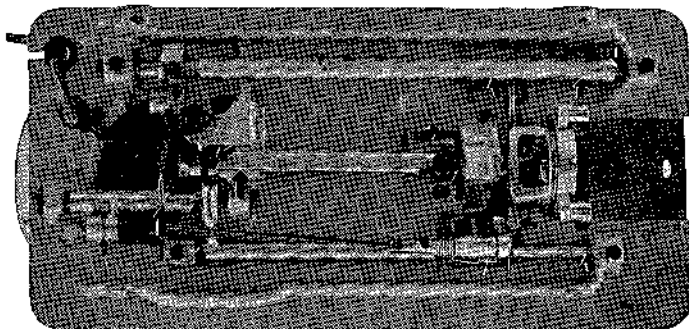

CARE AND ADJUSTMENT OF MOTOR

1) ATTACHING THE MOTOR TO THE MACHINE

Place the motor bracket (A) on the boss (B) on the arm, with which the slot in the motor bracket fits.

Then insert the screw (C), and after shifting the motor upward as far as it will go, tighten the screw. (Fig. 1)

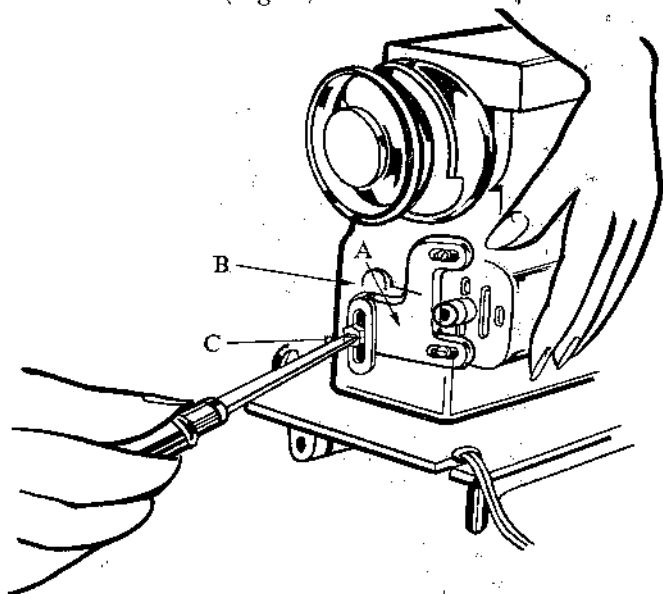

2) PLACING THE BELT ON THE MOTOR

Slip the belt into the groove in the balance wheel, and force it into the groove in the motor pulley. (Fig. 2)

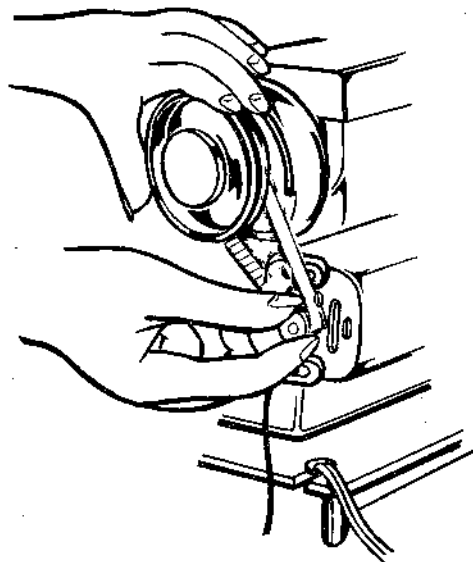

3) *REGULATING THE BELT TENSION ON THE MOTOR*

To adjust the belt tension, loosen the attaching screw about one turn with a screwdriver.

This will allow the motor to drop downward.

Then firmly tighten the screw, and the belt should have the correct tension.

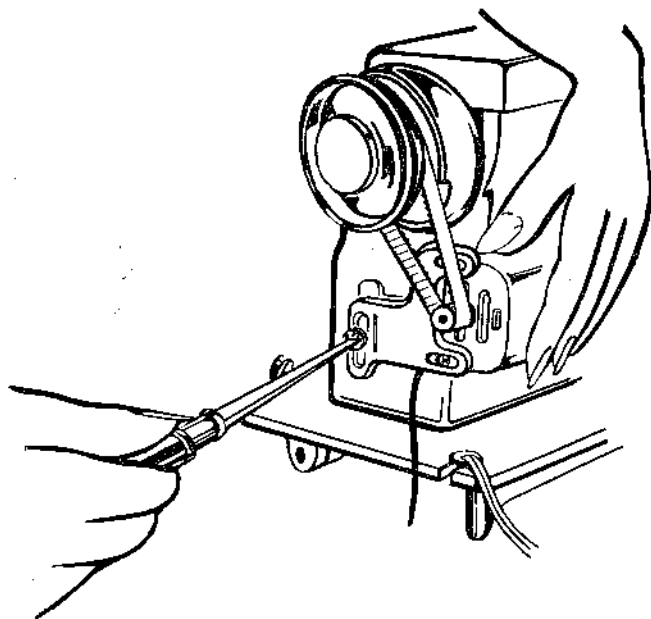

SUGGESTIONS FOR SMOOTH SEWING

Machine Working Heavily

See if the shuttle race, feed dog and underneath parts of the needle plate are clogged with lint. If so, clean out the part.

If the machine works hard after standing for some time, apply a little paraffin in place of oil.

Then run the machine rapidly to clean the bearings, and oil the machine with sewing machine oil. The use of inferior oil is usually the cause of the machine working heavily.

Thread Breaks

If the needle thread breaks, it is probably due to one of the following causes:

The machine being improperly threaded.

The tensions being too tight.

The needle being bent or having a blunt point.

The thread take-up spring broken.

If the lower thread breaks, adjust the bobbin thread tension; also see that the inside of the bobbin case and the underneath part of the tension spring are free from lint.

SUGGESTIONS FOR SMOOTH SEWING

Skipped Stitches

A bent or blunt pointed needle is often the cause of this. See that the needle is accurately inserted. Remove the needle plate, and, after ascertaining that the feed is clean and working freely, reset the needle plate.

Needle Breaks

See that the needle is not bent and avoid pulling the material when stitching; either condition will cause the needle to strike on the needle plate and break.

Material Puckers

This is generally due to incorrect tension. See that both the bobbin case and the needle are properly threaded; that the thread used is of good quality and the correct size for the needle.

Stitches Loop

This is regulated by the tensions. See that both the bobbin case and the needle are properly threaded; that the thread used is of good quality and the correct size for the needle.